

LCD Drawer & KVM Benefits

- ▶ Ultra high resolution 1600 x 1200
- ▶ High density Cat5 KVM with either 16 or 32 ports in 2U
- ▶ Cost efficient DB-15 KVM integration
- ▶ Mix PS/2, USB & SUN with Multi- Platform switch capability
- ▶ Secure remote user access across the world wide web



Drawer Features & Options

- 2U rackmount drawer with a 20" SAMSUNG LCD
- Either PS/2 or USB input to the LCD drawer by cable selection
- Multiple keyboard language selections with either touchpad or trackball
- Slide rails with fixed positions to prevent drawer movement when typing
- Multi lingual on screen display menu
- 12, 24 and 48 volt DC power options

Options:



Designed for:



Monitor Grade A industrial TFT LCD panel

- 20" 1600 x 1200 LCD with 300 nit brightness and 800:1 contrast ratio typical

Diagram

Unit : mm

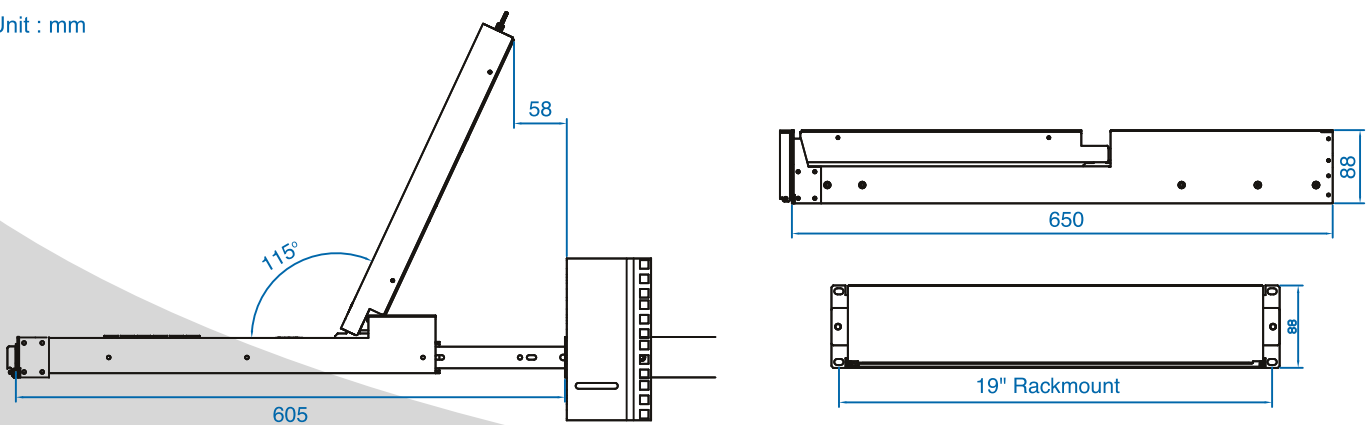

Dimensions

Model	Product Dimension (W x D x H)	Packing Dimension (W x D x H)	Net Weight	Gross Weight
20 Series	442 x 650 x 88 mm 17.4 x 25.9 x 3.5 inch	583 x 796 x 215 mm 23 x 31.3 x 8.5 inch	20 kg / 44 lbs	26 kg / 57 lbs

Item	Description		
LCD Manufacturer			
Diagonal Size	17" TFT	19" TFT	20" TFT
Max. Resolution	1280 x 1024	1280 x 1024	1600 x 1200
Brightness (cd/m ²)	300	300	300
Color Support	16.7 M	16.7 M	16.7 M
Contrast Ratio (typ.)	1000:1	1000:1	800:1
Viewing Angle (H/V)	160° x 160°	160° x 160°	160° x 160°
Display Area (mm)	338 x 270	376 x 301	408 x 306
Tr Response Time (ms)	1.3	1.3	1
LCD Panel MTBF (hrs)	50,000	50,000	50,000
VGA Signal Input	Analog RGB, 0.7Vp-p		
Sync. Type	Separate H/V, Composite, SOG		
Resolution	720 x 400, 70 Hz		
	640 x 480, 60/ 72/ 75 Hz	640 x 480, 60/ 70/ 72/ 75 Hz	
	800 x 600, 60/ 70/ 72/ 75 Hz		
	1024 x 768, 60/ 70/ 75 Hz		
	1152 x 864, 60/ 70/ 75 Hz		
	1280 x 720, 60/ 70/ 75 Hz	1280 x 720, 60/ 75 Hz	
	1280 x 1024, 60/ 70/ 72/ 75 Hz	1280 x 1024, 60/ 70/ 75 Hz	
	-	1440 x 1050, 60 Hz	
	-	1600 x 1200, 60 Hz	
Plug & Play DDC	EDID 1.3		
Connection	DB-15 connector		
Power Input	Auto-sensing 100 to 240VAC, 50 / 60Hz		
Power Consumption	Max. 48 Watt, Standby 5 Watt		
Compatibility	Multi-platform - Mix PCs, SUNs, IBMs, HPs & DELLs.		
Regulation Approval	FCC, CE		

Options

DC Power	DC power input with 12V, 24V, 48V selection
----------	---

Environmental

Operation	0° to 50°C Degree
Storage	-5° to 60°C Degree
Relative Humidity	5~90%, non-condensing
Shock	10G acceleration (11ms duration)
Vibration	5~500Hz 1G RMS random vibration